

Outdoor Cabinets



DESCRIPTION

Sharkcrack Outdoor Cabinets are designed for installations where increased durability and IP65 ratings are required such as harsh outdoor weather conditions and within factory environments where dust and water may be present.

FEATURES

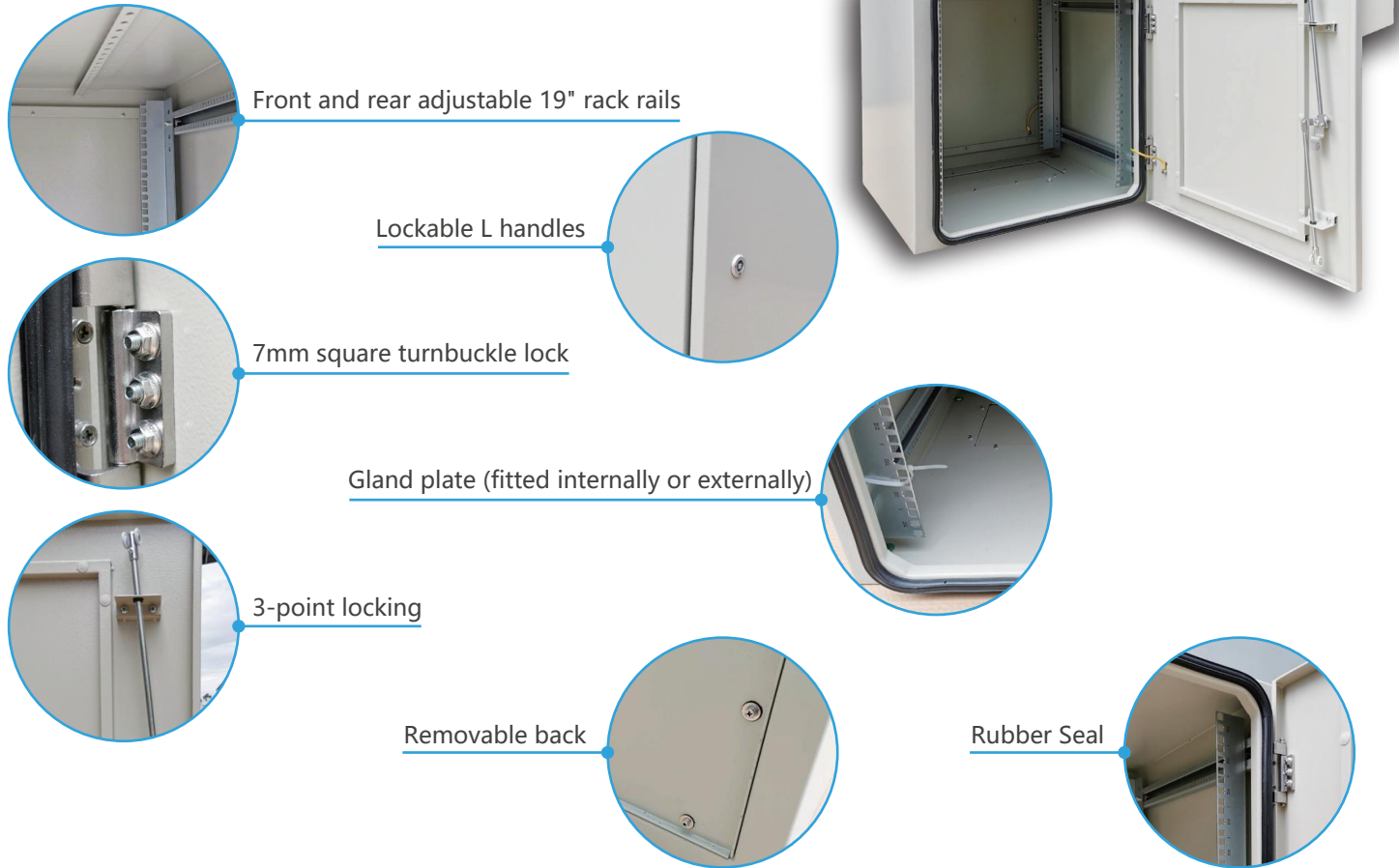

SPECIFICATIONS

- 19" cabinet installation system designed to protect sensitive equipment from harsh environments.
- Suitable for protecting equipment from dust and water.
- Designed to accommodate small to medium passive patching networks.
- Easy cabling via gland plate.
- Front or rear depth adjustable 19" rack rails.
- Manufactured from 2.0 mm electrophoresis and powder coated steel.
- Front and rear adjustable 19" rack rails.
- Gland plate (fitted internally or externally).
- 7mm square turnbuckle lock.
- Lockable L handles.
- 3-point locking.
- Removable back.
- Earth strap kit.



Outdoor Cabinets

TECHNICAL DRAWINGS

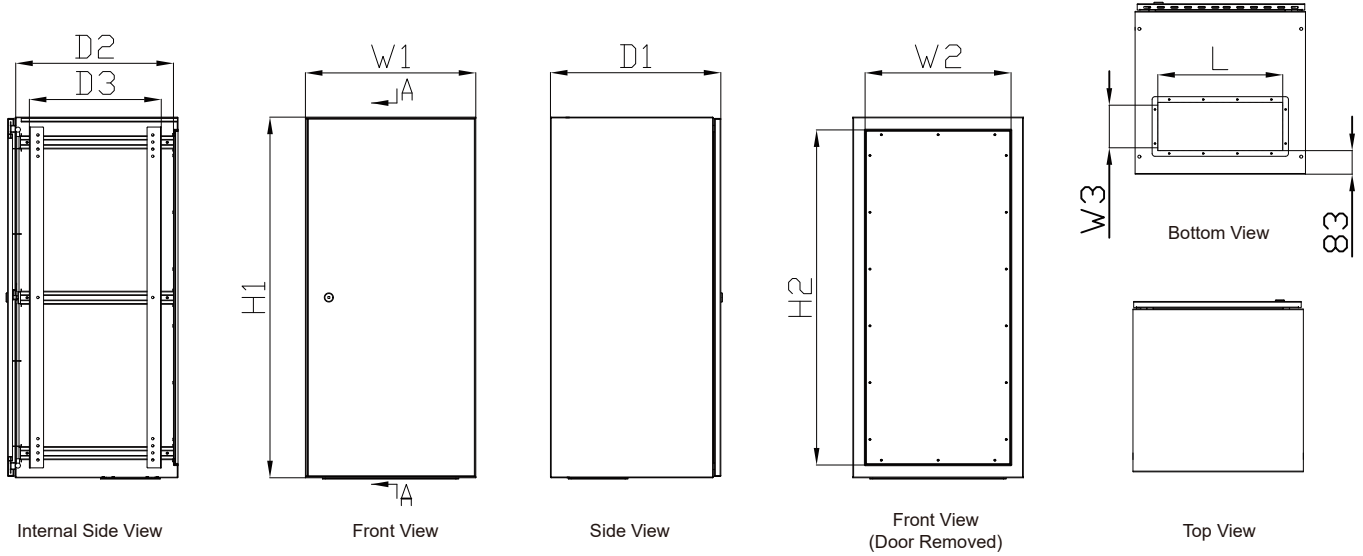

CONFIGURATIONS AND DIMENSIONS

			External				Internal	Back Opening Size		Cable Entry Size	
			Height	Width	Depth	Available Depth	Depth	Height	Width	Length	Width
Product Material	SKU	Rack Unit	H1	W1	D1	D2	D3	H2	W2	L	W3
Galvanized CRS + Electrophoresis + Powder Coating	SCBIP12U66	12	600	600	600	555	465	507	511	440	170
	SCBIP18U66	18	870	600	600	555	465	777	511	440	170
	SCBIP27U66	27	1270	600	600	555	465	1177	511	440	170
	SCBIP42U66	42	1950	600	600	555	465	1857	511	440	170

ACCESSORY

Powder Coated Plinth

Designed for the cabinet when installing on the floor.

SKU	Dimensions (mm)			SCBIP12U66	SCBIP18U66	SCBIP27U66	SCBIP42U66
SCBIPPL66	Height	Width	Depth	●	●	●	●
	80	600	600				

Technical Drawings

